

Cirrus 5

Maintenance Manual



 **3B™ Medical, Inc.**

Contents

External Components	2
Internal Components	3
Disassembly/Replacement of Major Components	4
Theory of Operation.....	7
Electrical Components-Specs/LCD.....	8
Troubleshooting.....	10

◆ External Components

Referring to Figure 1 & 2, in Table 1.

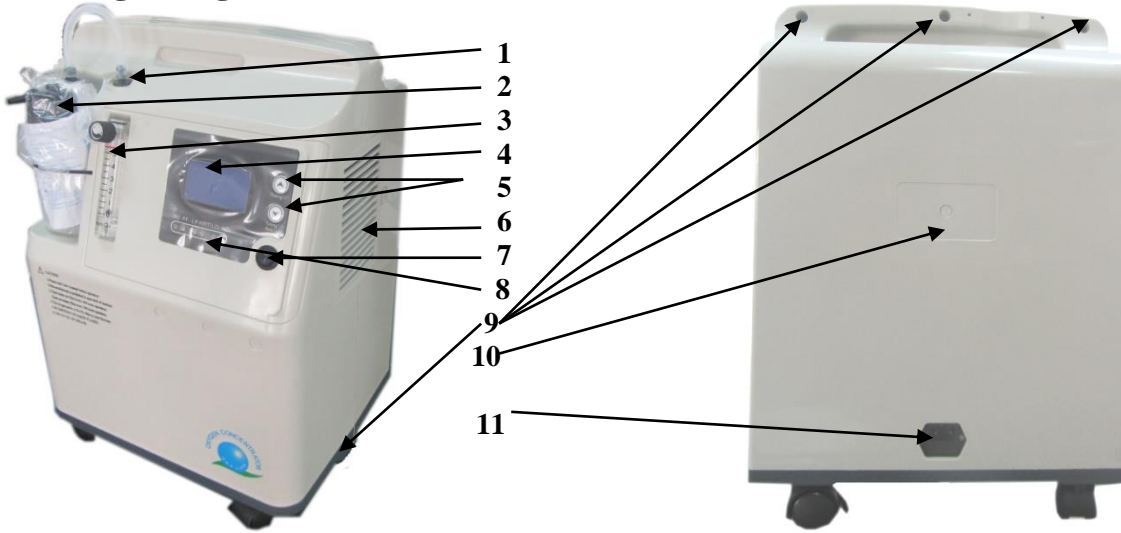

Figure 1

Figure 2

1	Oxygen Outlet	6	Cabinet Intake Filter	11	AC Power Cord Socket
2	Humidifier (optional)	7	Power Switch		
3	Flow Meter	8	LED Indicators		
4	LCD Display	9	Rear Panel Screws (5)		
5	Display Buttons	10	Model/SN Label		

Table 1

• **Internal Components**

Location of major components in Figure 3 & 4, in Table 3.

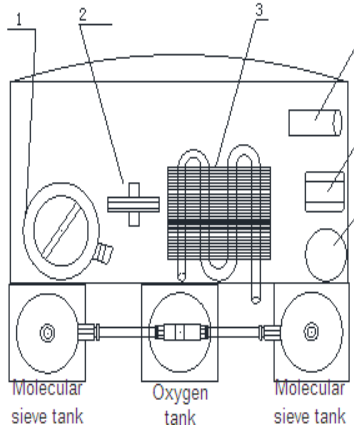

Figure 3

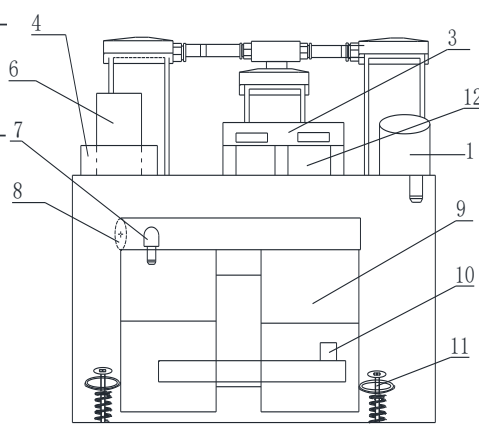

Figure 4

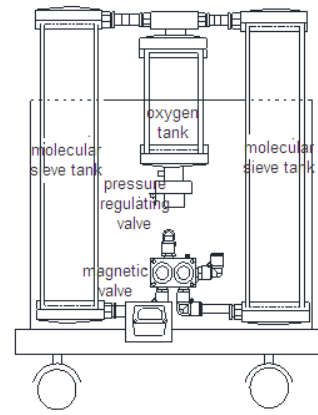

Figure 5

1	Compressor Inlet Filter	6	Exhaust Dampener	1	Compressor Shock Mounts
2	Bacterial filter	7	Compressor outlet	1	A/C Cooling Fan
3	Cooling system	8	Safety valve	2	
4	Capacitor	9	Compressor		
5	Transformer	10	Compressor inlet		

Table 3

• **Disassembly of Major Components**

• **Removing Back Panel**

- Remove AC Power Cord. Locate and remove the 5 screws securing the back panel. Slide back panel away from front panel and set aside.

• **Removing Front Panel**

- Disconnect PCB board connectors, Fan connector, Transformer connector, Compressor connector, Magnetic valve four-pin connector, Power failure two-pin connector. Disconnect silicone rubber tube on pressure sensor board and flow meter.

• **Disassembly of Molecular Sieve Beds and Oxygen Tank**

- Press down blue/white ring of the quick connector, and pull out connecting pipe between molecular sieve tank and oxygen tank.
- Remove the screws located between molecular sieve tank and compressor. Pull out the connecting pipe between molecular sieve tank and magnetic valve. Remove molecular sieve tank.
- As oxygen storage tank is removed, remove the screws between compressor cabinet, then pull off connecting pipe between casing and flow meter, remove molecular sieve tank.

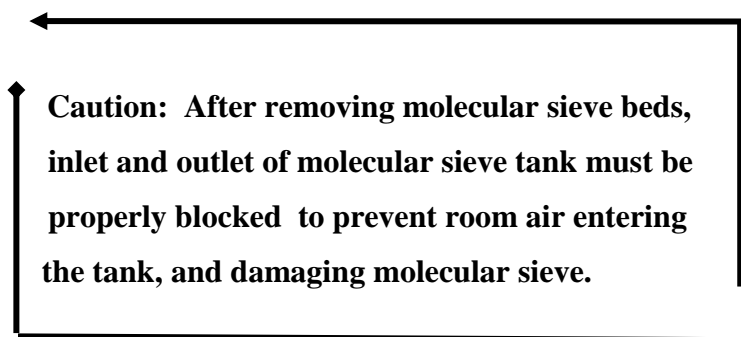

Caution: After removing molecular sieve beds, inlet and outlet of molecular sieve tank must be properly blocked to prevent room air entering the tank, and damaging molecular sieve.

- **Disassembly of the Magnetic Valve**

- Disconnect exhaust tube and air intake tube connecting magnetic valve.
- Press down blue ring of the quick plug connector from molecular sieve tank and connecting tube between molecular sieve tank and magnetic valve (inlet of molecular sieve tank must be sealed to prevent room air from entering sieve tank). Disconnect power supply line from control panel to remove magnetic valve.

- **Disassembly Pressure Regulating Valve**

- Pull off the silicone tube between pressure regulating valve and flow meter. Revolve out the pressure regulating valve from oxygen tank by clockwise direction (see from top to bottom) to take out pressure regulating valve.

←

Caution: When carrying out installation, raw adhesive tape should be wound or silica gel is coated properly on the thread of pressure regulating valve to tighten the pressure regulating valve.

- **Disassembly of the Safety Valve**

- Take off left side panel on the compressor cabinet (facing oxygen machine), then unscrew safety valve using #14 wrench/spanner

←

Caution: When mounting, raw adhesive tape should be twine properly on the thread of safety valve, and tighten the safety valve

- **Removing Exhaust Silencer**

- Remove side panel from compressor cabinet. Carefully hold exhaust tube connector and rotate exhaust silencer in counterclockwise direction.

- **Removing Compressor Inlet Filter**

- Open cabinet filter cover. Turn filter ¼ turn counterclockwise. Remove filter assembly from intake port.



- **Removing Compressor**

- Remove rear panel by removing 5 rear panel screws. Remove front panel by disconnecting tubing and electrical connectors.
- Disconnecting tube between compressor and air filter, exhaust silencer, and heat exchanger.
- Remove side panels from compressor cabinet. Unscrew four shock mount bolts on compressor mount. Remove compressor.

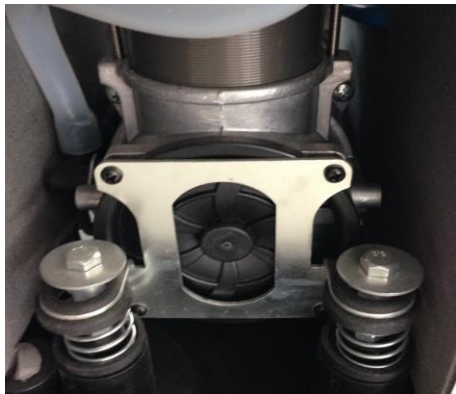

- **Replacing capacitor**

- Remove screws securing capacitor. Disconnect capacitor connecting capacitor to compressor. Replace with new capacitor.

- **Removing Flow meter**

Remove rear panel. Remove two tubes on flow meter. Remove screws securing the flow meter. Remove flow meter.

- **Removing the PCB**
 - Remove rear panel. Disconnect connector pin and tube on PCB board. Remove screws securing PCB. Remove PCB board.
- **Removing LCD panel**
 - Remove rear panel. Disconnect LCD panel connector on PCB board. Remove screw securing LCD panel. Remove LCD.
- **Removing Button Circuit Board**
 - Remove rear panel. Disconnect electrical connector from the Button Circuit Board and Control Panel. Remove screw and remove Button board.
- **Removing Indicator LED light**
 - Remove rear panel. Disconnect electrical connector from the LED light and control panel. Remove screw securing the indicator LED light panel and remove.
- **Removing Castor**
 - Access bottom of the unit. Remove screw securing castor.

- **Theory of Operation**

- The oxygen machine uses advanced PSA (Pressure Swing Adsorption) principle

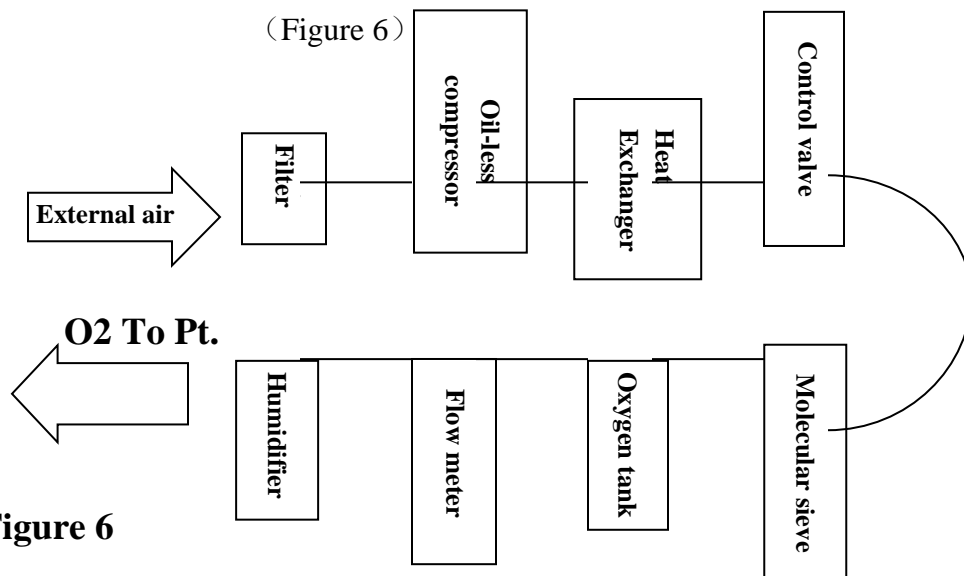

Figure 6

- **Electrical Components-Specs/LCD**

- **Block Diagram of Circuit Board** (please see Figure 7)

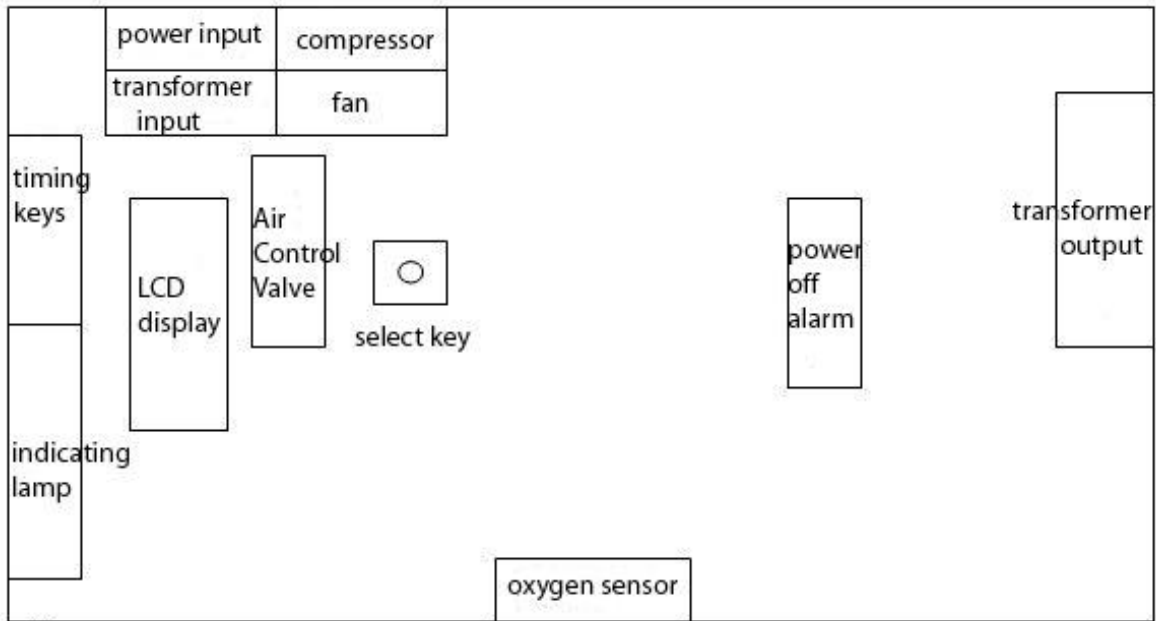

Figure 7

- **LCD display and Description for Regulating Circuit Board**

- LCD Display
 - S. Times: Session times
 - O.P. PSI: System pressure
 - O. Time: Session Operating Time (left four digitals indicate hour, last two digitals indicate minute)
 - ACC Time: Accumulated (Total) working hours (calculated as hours)

See Figure 8



Figure 8

• **Electrical/Pressure/Noise Specifications**

1. Compressor is oil-free compressor: Voltage: 120(AC) Frequency: 60Hz
2. Output pressure of oxygen: 5 PSI – 10 PSI (+/- 2 PSI)
3. Starting pressure of safety valve: 36 PSI
4. Output oxygen purity: 90% +/- 3 %
5. Noise Level: >40 dBA

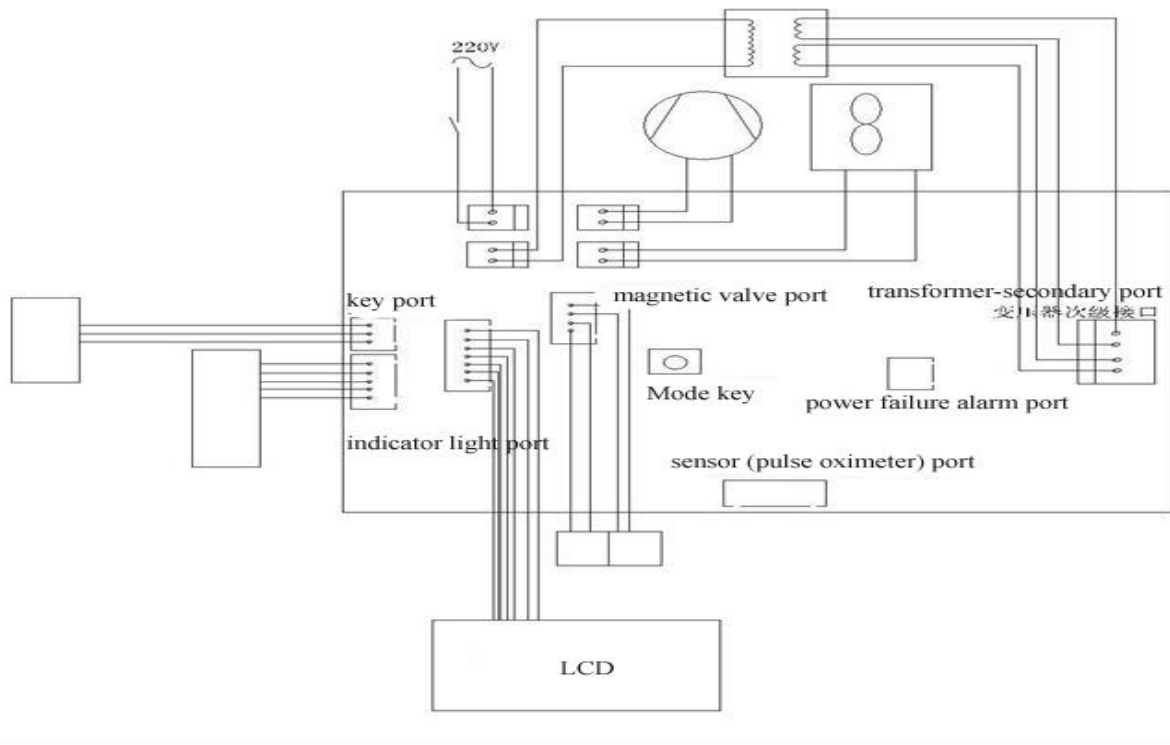

Troubleshooting Guide

- **Fault 1:**

Problem: Concentrator does not operate with no power on indicating lamp.

Most Likely Cause: No power.

Troubleshooting: Ensure unit is properly connected to power. Check fuse located in AC Power Cord receptacle.

- **Fault 2:**

Problem: Machine does not operate, but power on indicating lamp is lit.

Most Likely Cause: Compressor Capacitor is defective or Compressor is defective.

Troubleshooting: Remove rear panel. Check if there is 120V for compressor power supply on the PCB. If no, possible defective PCB. If yes, remove Compressor Capacitor, and detect if the Capacitor is defective by checking with a Volt Meter or replace another capacitor. If Capacitor checks OK, compressor may be defective. Replace compressor.

- **Fault 3:**

Problem: Output Flow low.

Most Likely Cause: 1. Check for leak in humidifier bottle (if connected). 2. Check proper operation of Flow Meter. 3. Check Output Pressure (5 PSI – 10 PSI +/- 2 PSI).

Troubleshooting: Remove rear panel. Use a pressure gauge to test the pressure between the flow meter and pressure regulating valve. Using a screw driver, adjust the pressure regulating valve until the pressure gauge indicates 5 PSI.

- **Fault 6:**

Problem: Concentrator is running, but no outlet flow (ball does not move in flow meter). There is a continuous audible alarm and “LP” led indicator is lit

Most Likely Cause:

1. Flow meter knob was tightly closed or damaged.
2. Large leak inside the machine. Inspect flow meter, pressure regulating valve, oxygen storage tank, radiator or other major components)

Troubleshooting: 1. Flow meter knob was tightly closed or damaged. Check flow meter knob for damage and to ensure it is able to be properly turned counterclockwise (on). If not, replace flow meter.

2. Large leak inside the machine. Inspect flow meter, pressure regulating valve, oxygen storage tank, radiator or other major components)

- **Fault 7:**

Problem: Oxygen concentration is low (out of spec)

Most Likely Cause:

1. Air intake occluded
2. Compressor defective.
3. Exhaust outlet occluded
4. Internal Leak
5. Defective/Improper function of molecular sieve bed.
6. Defective Circuit Board
7. Switch valve is defective.

Trouble shooting method: (See Flow Chart on next page)

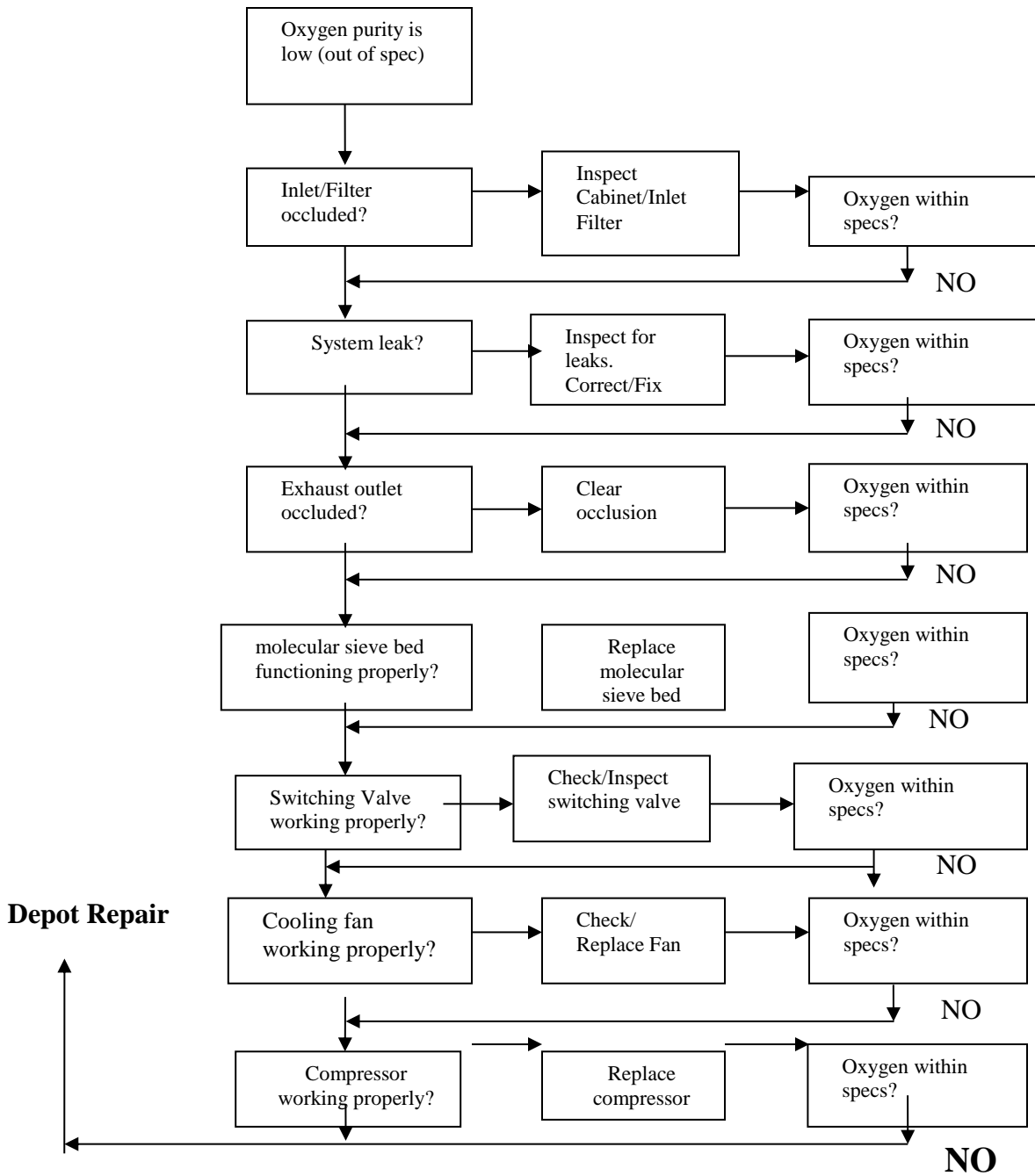

• **Fault 8**

Problem: There is large vibration when oxygen machine is working

Most Likely Cause: 1. Improper installation of the intake-tube between air intake filter and compressor. 2. Improper installation of compressor exhaust dampener assembly.

Trouble shooting method:

1. Readjust the position of air intake filter and intake-tube.
2. Remove the side panel of compressor and ensure compressor exhaust dampener is properly installed.



**799 Overlook Drive
Winter Haven, FL 33884
www.3Bproducts.com**